

T-ISS RELEASE HOOK PX-03

MANUAL RELEASE HOOK FOR RESCUE BOATS



T-ISS Helmkamp 32-34, 7091HR, Dinxperlo, The Netherlands. +31 315 656060, sales@t-iss.com

T-ISS – PX-03 Release hook for Rescue boats

Helmkamp 32-34, 7091HR Dinxperlo, The Netherlands

+31 (0)315 - 656060

sales@t-iss.com

www.t-iss.com

Index:

1. The T-ISS PX03 Release hook.	Page 2.
2. Installation & maintenance records.	Page 3.
3. Safety instruction.	Page 4.
4. Technical specifications.	Page 5.
5. Installation & operating guide.	Page 6.
6. Instructions for maintenance.	Page 7.
7. Diagram and spare part list.	Page 8.

1. THE T-ISS PX03 RELEASE HOOK.

The PX-03 release hook meets the high SOLAS standards for release hooks, as described in the MSC.81(70) and applicable LSA code, and is dimensioned to suspend davit launched rescue boats with a davit load not exceeding 1.500 kg.

For your information:

- Use non-rotating wire rope.
- Use a painter line where possible.
- Use a shackle $\varnothing 19$ mm up to $\varnothing 27$ mm.

During installation of the hook, only the top shaft should be disassembled. Full disassembly of the hook can cause un-repairable damage to the system and dangerous situations which can lead to injuries or death of personnel.



2. INSTALLATION AND MAINTENANCE RECORDS.

Installation date			The 5 year life cycle starts after this date			
Monthly inspections year 1.	Date	Approve	Date	Approve	Date	Approve
Monthly inspections year 2.						
Monthly inspections year 3.						
Monthly inspections year 4.						
Monthly inspections year 5.						
The hook now needs to be replaced or overhauled by an authorized provider, please contact us at sales@t-iss.com for authorized providers.						

3. SAFETY INSTRUCTION.

For your safety, please carefully read the instruction before using the release hook to prevent improper operation and to ensure your personal safety. For a safe operation, all operators and persons involved in installation, maintenance and operation of the PX-03 release hook must familiarize themselves with this instruction manual to ensure they are familiar with the system functions and know how to use them. The hook should only be operated by persons who understand the functionalities and routines. We advise to make this manual easily available on board for personnel working with the PX-03 release hook.

- Make sure that the operator understands the functionality of this release system completely to ensure it can be operated safely.
- Always check that the hook is in good shape before commencing a drill.
- If any hazardous condition is found, this needs to be reported immediately and the hook must be put out of operation.
- For maintenance and overhaul only original spare parts should be used.
- For maintenance and overhaul always use appropriate tools.

4. TECHNICAL SPECIFICATIONS.

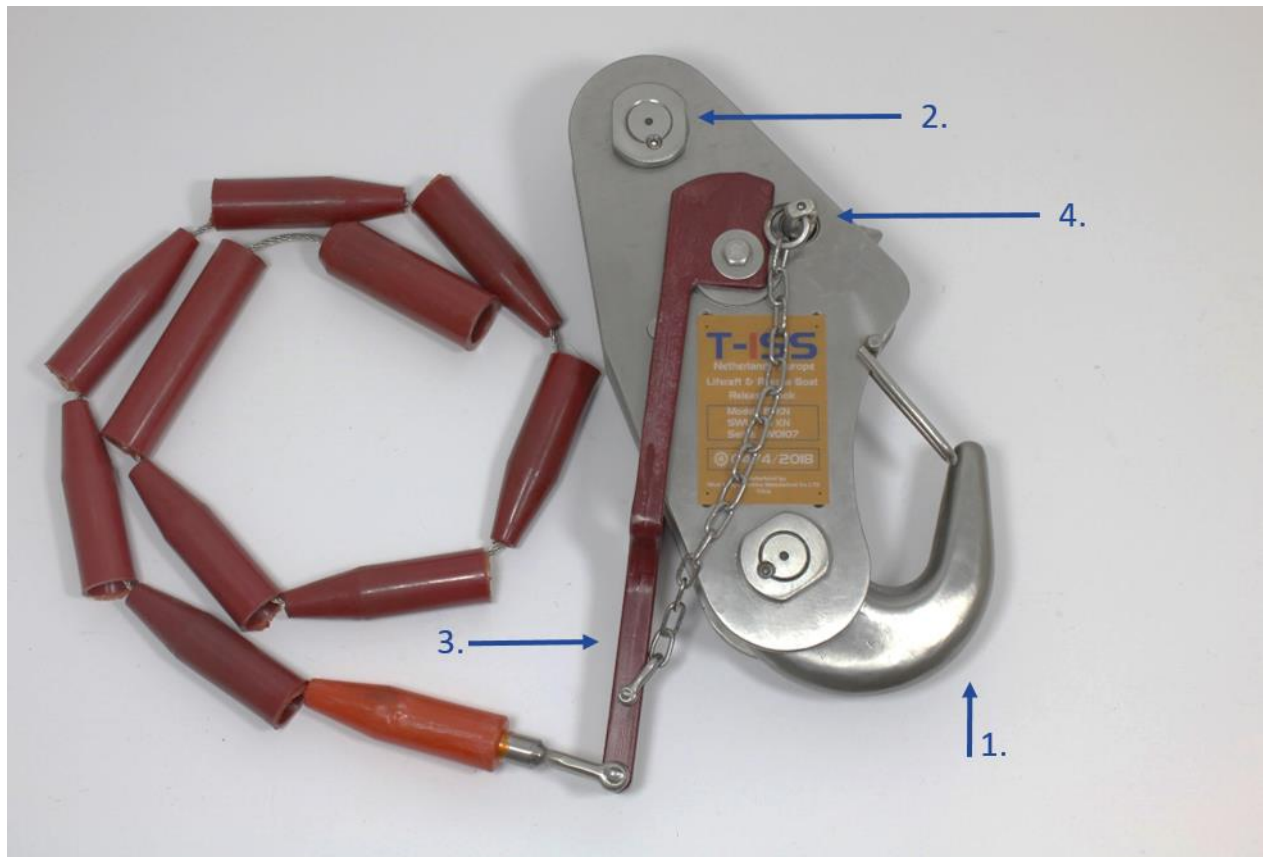

1	Lifting hook
2	Distance bush and shaft
3	Release handle
4	Safety pin

The PX-03 manual release hook is intended to be used on rescue boats. Manufactured in seawater resistant stainless steel. Pushing the release handle to the upward position releases the rescue boat. The Safe Working Load of the PX-03 is 1500kg.

5. INSTALLATION & OPERATING GUIDE.

Installation.

Installation of the hook is easy, disassemble the top shaft by removing the hexagonal securing screw, and unscrewing the nut which holds the shaft in position. Place the spliced eye or corresponding wire rope fall over the distance bush. Place the distance bush between the two side plates and place the shaft. Then make sure the shaft is fastened tightly and the hexagonal securing screw is put back in place.

Operation.

The PX-03 is a manual release hook. All hook handling can be done by one person. The hook is designed to be opened manually, just push the release handle in the upward position and the hook will open.

Connecting the link into the hook.

Before we place the suspension link into the hook, we must bring the release handle in the lowest position, by pulling the cord (make sure the safety pin is removed). Connect the hook and make sure the safety pin is back in its locking position (through the hook construction) so the hook cannot accidentally open, then place wire rope or link into the hook, by pushing it through the securing spring. The rescue boat can now be lowered.



When the rescue boat is waterborne, remove the safety pin from the hole, and push the red release handle to the upward position, the hook will release the wire rope or link.

6. INSTRUCTION FOR MAINTENANCE

This release hook requires frequent maintenance to ensure good working order in all conditions.

Preventive maintenance can be done by any of the crew members and consists of:

- Keeping the hook clean, by cleaning with regular soap and water.
- Keeping all moving parts lubricated.
- Check for, and adjustment of, wear and tear parts.

Always check the bow-shackle before use and make sure the tightening bolt are fit tightly. If the release hook will not be used for a longer period, please store it in the released position.

Maintenance regulations.

Below points must be followed to ensure the hook and its operation is in compliance with the regulations:

- Certificates, inspection and maintenance records must be kept and be available on-board.
- Replacement of parts must be carried out in accordance with the manufacturers requirements and standards.
- Maintenance time schedule as per below must be followed.
- The hook should only be disassemble/assembled by an authorized person.

	Weekly	Monthly	5-yearly
Clean and visual inspection, check for defaults.	x		
Lubricate moving parts.		x	
Check connection of wire rope to the hook.		x	
Check release cords (replace with original spare part, if damaged).		x	
Replace or overhaul the hook			x

7. DIAGRAM AND SPARE PART LIST. Only use original spare parts when maintaining the PX-03 release hook. All spare parts are available from T-ISS: sales@t-iss.com

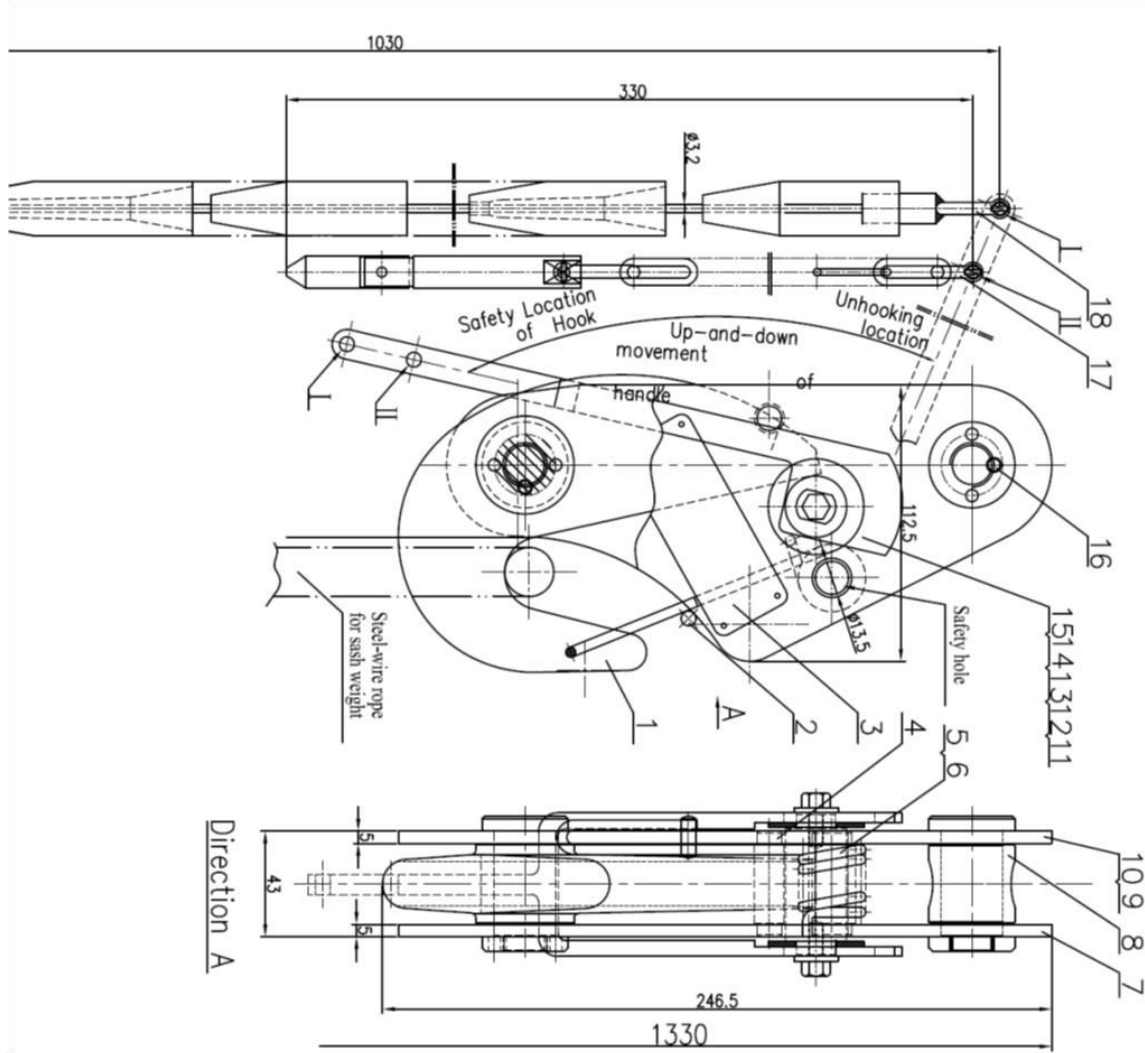

No	Drawing no	Name	Qty
19	GB3356-85	Inner hexagonal wrench	1
18	150NY-14	Adjustable push-bar unit	1
17	150NY-13	Safety device unit	1
16	GB77-85	Inner hexagonal fastening screw	2
15	GB5781-86	Hexagon screw	2
14	GB5848-85	Washer	2
13	150NY-12	Shift handle	1
12	150NY-11	Limit shaft	1
11	150NY-10	Gasket	2
10	150NY-09	Round nut	2
9	150NY-08	Pinle	2
8	150NY-07	Lifting lug	1
7	150NY-06	Right side panel	1
6	150NY-05	Torsional spring	1
5	150NY-04	Spring shaft	1
4	150NY-03	Locating pin roll	1
3		Index plate	1
2	150NY-02	Spring shaft	1
1	150NY-01	Lifting hook	1