

# T-**I**SS RELEASE HOOK

**AUTOMATIC RELEASE HOOK FOR LIFE RAFTS AND RESCUE BOATS**



T-ISS Helmkamp 32-34, 7091HR, Dinxperlo, The Netherlands. +31 315 656060, [sales@t-iss.com](mailto:sales@t-iss.com)

## T-ISS – PX-01 Automatic release hook for life rafts and rescue boats

Helmkamp 32-34, 7091HR Dinxperlo, The Netherlands

+31 (0)315 - 656060

sales@t-iss.com

www.t-iss.com

### Index:

1. THE T-ISS PX-01 RELEASE HOOK.	PAGE 2.
2. INSTALLATION & MAINTENANCE RECORDS.	PAGE 3.
3. SAFETY INSTRUCTION.	PAGE 4.
4. TECHNICAL SPECIFICATIONS	PAGE 5.
5. INSTALLATION & OPERATING GUIDE	PAGE 6.
6. INSTRUCTION FOR MAINTENANCE.	PAGE 8.
7. DIAGRAM AND SPARE PART LIST	PAGE 9.

### 1. THE T-ISS PX01 RELEASE HOOK.

The PX-01 release hook meets the high SOLAS standards for off-load release hooks, as described in the MSC.81(70) and applicable LSA code and is dimensioned to suspend davit launched life rafts up to 40 persons and rescue craft with a davit load not exceeding 3.500 kg. Remember that with this release hook, in both automatic and manual release modes, the actuating lever must be locked in the automatic release position just before the craft enters the water.

For your information:

- Use non-rotating wire rope.
- Use a painter line where possible.
- Use a shackle  $\varnothing$ 19 mm up to  $\varnothing$ 27 mm.

During installation of the hook, only the top shaft should be disassembled. Full disassembly of the hook can cause un-repairable damage to the system and dangerous situations which can lead to injuries or death of personnel.





## 2. INSTALLATION AND MAINTENANCE RECORDS.

Installation date			The 5 year life cycle starts after this date			
Monthly inspections year 1.	Date	Approve	Date	Approve	Date	Approve
Monthly inspections year 2.						
Monthly inspections year 3.						
Monthly inspections year 4.						
Monthly inspections year 5.						

The hook now needs to be replaced or overhauled by an authorized provider, please contact us at [sales@t-iss.com](mailto:sales@t-iss.com) for authorized providers.

**3. SAFETY INSTRUCTION.**

For your safety, please carefully read the instruction before using the release hook to prevent improper operation and to ensure your personal safety.

For a safe operation, all operators and persons involved in installation, maintenance and operation of the PX-01 release hook must familiarize themselves with this instruction manual to ensure they are familiar with the system functions and know how to use them. The hook should only be operated by persons who understand the functionalities and routines.

We advise to make this manual easily available on board for personnel working with the PX-01 release hook.

- Make sure that the operator understands the functionality of this release system completely to ensure it can be operated safely.
- Always check that the hook is in good shape before commencing a drill.
- If any hazardous condition is found, this needs to be reported immediately and the hook must be put out of operation.
- For maintenance and overhaul only original spare parts should be used.
- For maintenance and overhaul always use appropriate tools.

**4. TECHNICAL SPECIFICATIONS.**

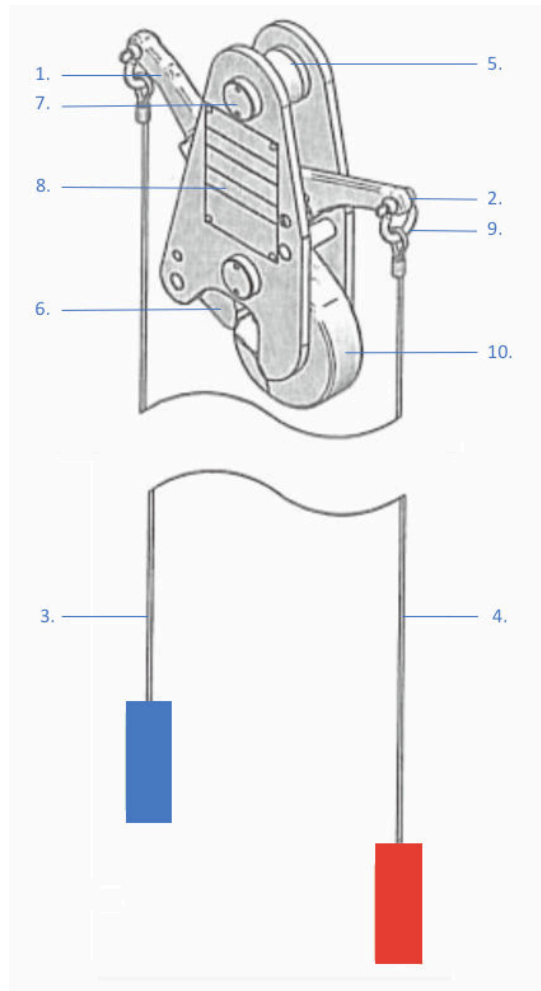

1	Actuating lever manual release
2	Actuating lever automatic release
3	Cord with blue handle for manual release
4	Cord with red handle for automatic release
5	Distance bush and shaft
6	Latch
7	Nut
8	Type plate
9	Bow shackle
10	Hook

The PX-01 manual/automatic release hook is intended to be used on rescue boats and life rafts only. Manufactured in seawater resistant stainless steel it is designed as an integrated manual and automatic release hook. The Red rope handle activates the automatic release, the Blue rope handle is for manual release. The Safe Working Load of the PX-01 is 3500kg.

## **5. INSTALLATION & OPERATING GUIDE.**

### **Installation.**

Installation of the hook is easy, disassemble the top shaft, place the spliced eye or corresponding wire rope fall over the distance bush. Place the distance bush between the two side plates and place the shaft. Then make sure the shaft is fastened tightly.

### **Automatic (Red rope handle) and manual (Blue rope handle) release.**

Before operating the PX-01 release hook make sure that both handles are in the upward position to ensure the hook is locked!

### **Automatic release/off-load release.**

The “Red rope handle” is designed for off-load release. This function is being used during all operations. When we activate the off-load release, the hook shall not open with a load in the hook less than 30 kg. When the load is released, the hook shall open (opening between 5 – 30 kg force). Common use is to pull the “Red rope handle” during lowering, just before the raft or rescue boat is waterborne. When waterborne, the hook will automatically open and the rescue boat can sail away from the vessel.

When lowering, pull the “Red rope handle” to activate the automatic release. When waterborne the load is taken away from the hook and it opens automatically.

### **Manual release/on-load release.**

The “Blue rope handle” is designed for on-load release till approximately 150 kg. For example, when the craft is waterborne, and there is a strong current, the craft can pull on the wire rope and therefore keep the load on the hook system. This means, that under these circumstances the off-load release system (“Red rope handle function”) will fail. Therefore, an extra on-load release (Blue rope handle) has been provided. This system can be activated by pulling the “Blue hand grip” and releases the hook always. Up to a weight of 150 kg, the required pulling force is approx. 60 kg.

### **Connecting the link into the hook.**

Before we place the suspension link into the hook, we must bring the hook back into working order. The following procedure must be followed:

- Swing (press firmly) the hook and release lever back into working position upwards.
- When ready for loading the hook, press the suspension link of the rescue craft into the hook.
- The latch will rotate up and the suspension link slides in to place and will be locked automatically. If the link is positioned incorrectly, we can release the hook by pulling firmly on the “Red hand grip”. Now we can reposition the hook as described above and place the link correctly.

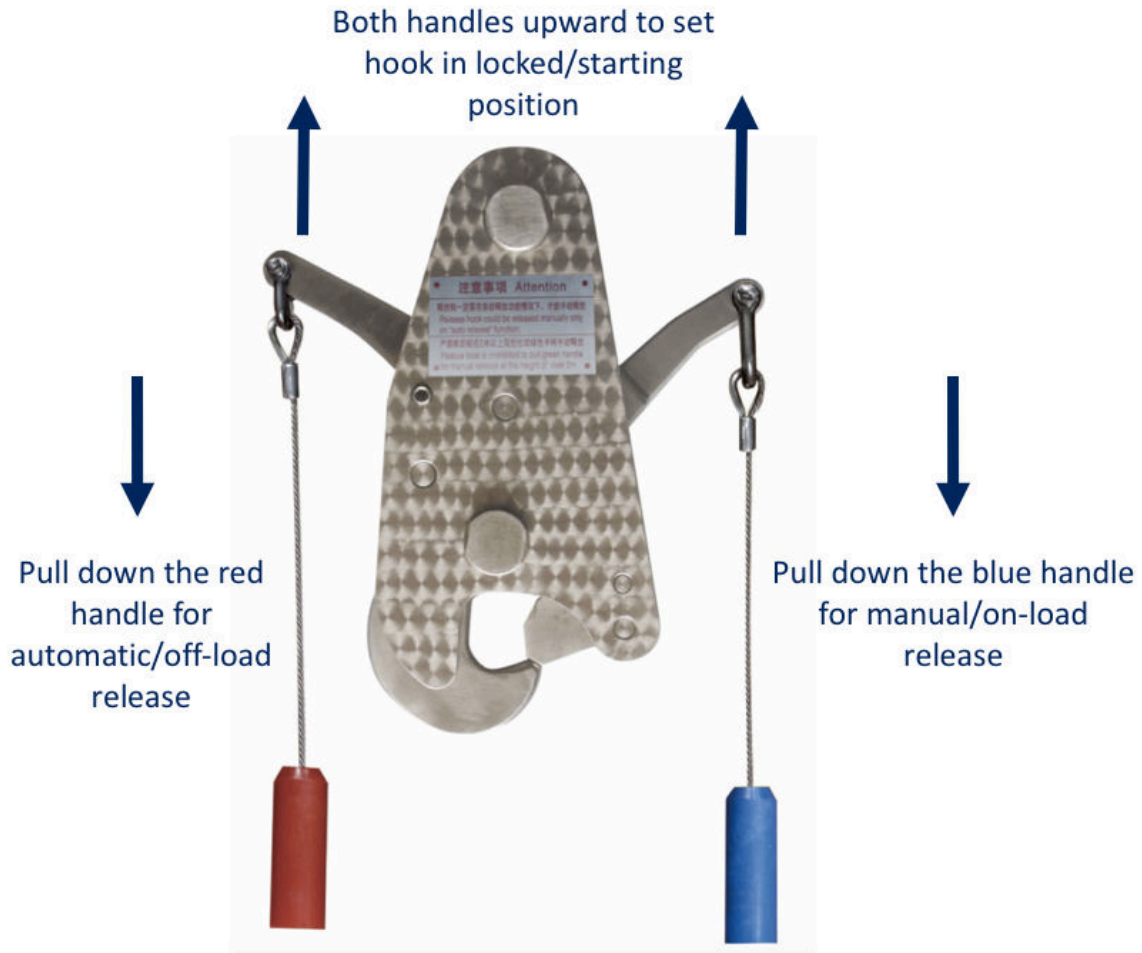

**6. INSTRUCTION FOR MAINTENANCE**

This release hook requires frequent maintenance to ensure good working order in all conditions.

Preventive maintenance can be done by any of the crew members and consists of:

- Keeping the hook clean, by cleaning with regular soap and water.
- Keeping all moving parts lubricated.
- Check for, and adjustment of, wear and tear parts.

Always check the bow-shackle before use and make sure the tightening bolt are fit tightly. If the release hook will not be used for a longer period, please store it in the released position.

**Maintenance regulations.**

Below points must be followed to ensure the hook and its operation is in compliance with the regulations:

- Certificates, inspection and maintenance records must be kept and be available on-board.
- Replacement of parts must be carried out in accordance with the manufacturer’s requirements and standards.
- Maintenance time schedule as per below must be followed.
- The hook should only be disassemble/assembled by an authorized person.

	Weekly	Monthly	5-yearly
Clean and visual inspection, check for defaults.	x		
Lubricate moving parts.		x	
Check connection of wire rope to the hook.		x	
Check release cords (replace with original spare part, if damaged).		x	
Check automatic release function.		x	
Replace or overhaul the hook			x

**7. DIAGRAM AND SPARE PART LIST.**

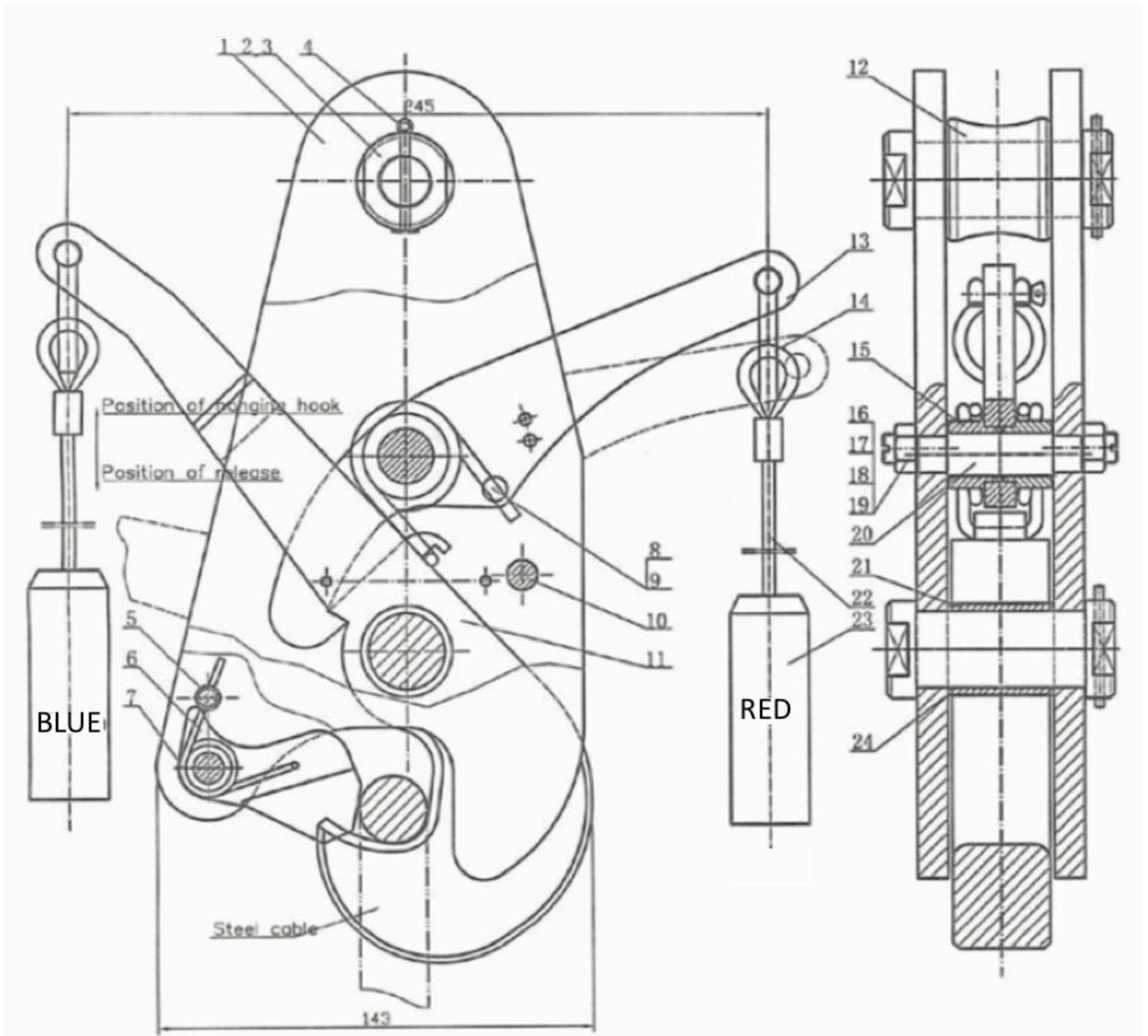

Only use original spare parts when maintaining the PX01 release hook. All spare parts are available from T-ISS.

Part No.:	Part Code.:	Description:	Quantity:
1	370NY-01	Left and right side plate	1
2	370NY-02	Axia pin	2
3	370NY-03	Screw nut	2
4	GB91-76	Cotter pin (3*45)	2
5	370NY-04	Catch spring axis pin	1
6	370NY-05	Latch	1
7	370NY-06	Double torsion spring	1
8	370NY-07	Double torsion spring	1
9	370NY-08	Catch spring axis	1
10	370NY-09	Fitting pin axis	2
11	370NY-10	Hook handle assembly	1
12	370NY-11	Roll	1
13	370NY-12	Controlling handle	1
14	GB10603-89	Bow shackle (6mm)	2
15	370NY-13	Check ring	2
16	GB52-76	Screw nut (M10)	2
17	GB73-76	Plot-end screw set (M10*33)	2
18	370NY-14	Spring	2
19	GB308-64	Steel ball (6mm)	2
20	370NY-15	Handle axis	1
21	370NY-16	Copper sheeting bearing	1
22	370NY-17	Handle steel wire rope	2
23	370NY-18	Handle	2
24	GB96-76	Spacer (25mm)	2
25	370NY-19	Label	1