



SOLAS MARITIME SAFETY TAPES

T-ISS
Safety Suppliers

T-ISS
Safety Suppliers



SOLAS MARITIME SAFETY TAPES

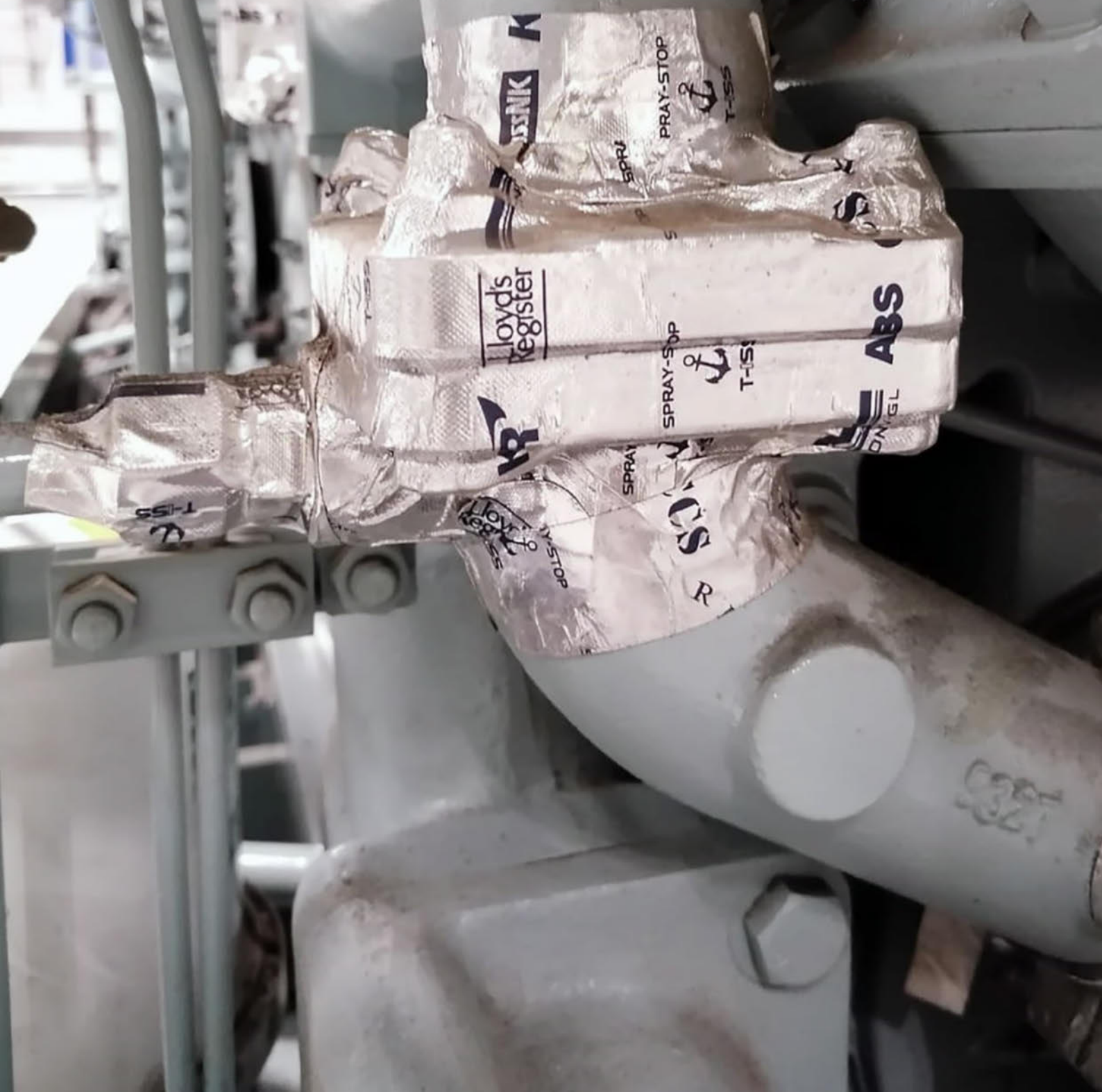

INTRODUCTION

Life-saving products are of great importance in operating safely at sea, whether on a ship or at an offshore location. Choosing the right equipment to protect your personnel, guests or materials is the most important task of any ship owner or offshore asset owner, while always looking for value-for-money: the highest quality for the lowest price.

Certified and approved safety products that you can rely on

We offer a selective range of Safety Products for the marine and offshore market to protect your people and your business. All of our products come with all the required certificates and approvals and are priced on a very competitive level. We aim to be at the forefront of maritime safety and are constantly developing (both inhouse and in cooperation with our trusted partners-suppliers) new products based upon our solid reputation for quality and innovation. One thing we never compromise on, is our quality. All our maritime safety products meet the strictest standards for design, testing, documentation, are compliant with local regulations and international standards. T-ISS offers safety products that are cost-efficient, easy to use and above all, will give the owner and user peace of mind. All our maritime safety products are globally available through an extensive network of stockists and distributors.

Our experience and quality is your advantage

T-ISS was established in 2003 and is an ISO9001:2015 approved company. The people behind the company have decades of experience in the Marine Industry. We perfectly understand the importance of reliable, accessible and good price-quality ratio products, services and turn-key solutions. Our products meet all the international quality standards and hold all the relevant certificates and approvals. As a result, they are recognized by most benchmark systems and regulatory authorities.

Environment, health and safety

T-ISS as a company is dedicated to environmental safety and health, at all levels of its operations, from manufacturing to installation. Because of this, we have our own Environmental, Health and Safety policies. These are part of the T-ISS company policy, and reflect our principles of running a sustainable business.

- Creating a safe working environment for all employees and stakeholders
- Minimizing the carbon footprint
- Integrating EHS elements into T-ISS Research & Development strategies for all company products and systems
- Continuous measurement, monitoring and improvement of EHS performance





TABLE OF CONTENT

SOLAS MARITIME SAFETY TAPES

- Introduction 3
- Spray Stop Anti-Splashing Tape 6
- Spray Stop Anti-Splashing Tape 50+ 7
- Spray Control Tape 8
- Drip Stop Tape - Non Leak Tape 9
- Pipe Repair Tape 10
- SolasFlex Retro Reflective Tape 12
- Marine Reflective Tape 13
- Safety Marking Tape Reflective 14
- Anti-Slip Tape 15
- Floor Marking Tape 16
- Barrier Tape 17
- LightLine Photoluminescent Tapes 18
- Safety Marking Tape Photoluminescent 20
- Security Seal Tape 21
- Biosoluble Heat Stop Tape 22
- Corrosion Stop Zinc Tape 23
- Rust Stop Petro Tape 24
- Hatch Cover Blueliner Tape 25
- Foam Mounting Tape 26
- Heat Prevention Tape 27

SPRAY STOP ANTI-SPLASHING TAPE



General description

T-ISS Spray Stop Anti-Splashing Tape is used for applications in the marine & offshore industry. This high-tech laminated multilayer aluminium tape, has been designed by safety specialists in order to prevent spray outs of hazardous liquids (oil / fuel) from tubing systems. These liquids can cause extremely dangerous situations like fires, explosions or other dangerous situations. According to SOLAS regulations, ships should apply appropriate protection to prevent leakage / splashing of flammable oil from FO, LO hydraulic and other systems. SprayStop is also tested for Methanol powered ships.

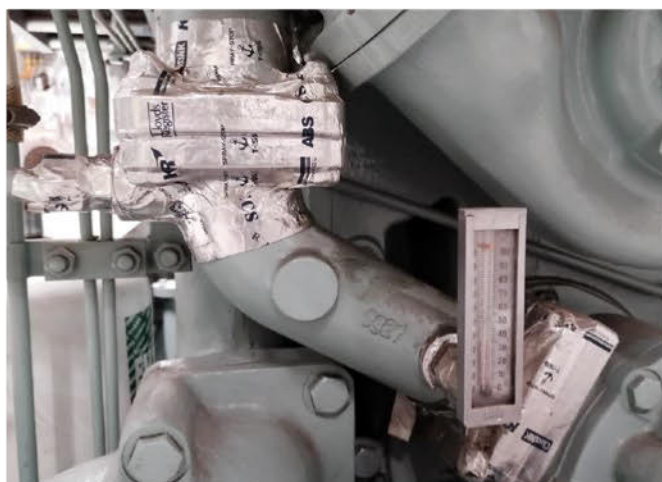

Technical data

Maximum pressure: 15 bar
 Maximum temperature: +160 °C continuously
 +200 °C shortly
 Adh. material tolerance: - 70 °C up to 200 °C
 Adhesion: 1000 g / 25 mm
 Shelf life: 3 years

Note; other widths available on request

Approvals

- Bureau Veritas, Lloyd's Register, DNV, RINA, ClassNK, ABS, KR, CCS

Standards

- Complies with the IMO A653 (16)

Article number	Description	Dimensions	Weight	IMPA
SPST0035	Spray Stop Tape	35 mm x 10 m	0,13 kg	871801
SPST0050	Spray Stop Tape	50 mm x 10 m	0,19 kg	871802
SPST0075	Spray Stop Tape	75 mm x 10 m	0,28 kg	871808
SPST0100	Spray Stop Tape	100 mm x 10 m	0,38 kg	871804
SPST0140	Spray Stop Tape	140 mm x 10 m	0,53 kg	871803
SPST0250	Spray Stop Tape	250 mm x 10 m	0,94 kg	871807
SPST0500	Spray Stop Tape	500 mm x 10 m	1,88 kg	871805
SPST1000	Spray Stop Tape	1000 mm x 10 m	3,75 kg	871806

SPRAY STOP ANTI-SPLASHING TAPE 50+



General description

T-ISS Spray Stop Anti-Splashing Tape 50+ has a slight difference compared to the regular version. Standard Spray Stop Tape will hold pressure up to 15 bar. Spray Stop Anti-Splashing Tape 50+ extends this limit to 50 bar. This means the tape will be particularly suitable for tubing systems that transport liquids under high pressure. Of course this tape can be used under the same circumstances as our standard Spray Stop Anti-Splashing tape.

Technical data

Maximum pressure: 50 bar
 Maximum temperature: +160 °C continuously
 +200 °C shortly
 Adh. material tolerance: - 70 °C up to 200 °C
 Adhesion: 1000 g / 25 mm
 Shelf life: 3 years



Note; other widths available on request

Approvals

- Bureau Veritas, Lloyd's Register, DNV, RINA, ClassNK, ABS, KR, CCS

Standards

- Complies with the IMO A653 (16)

Article number	Description	Dimensions	Weight	IMPA
SPST50035	Spray Stop Tape 50+	35 mm x 10 m	0,19 kg	871801
SPST50050	Spray Stop Tape 50+	50 mm x 10 m	0,27 kg	871802
SPST50075	Spray Stop Tape 50+	75 mm x 10 m	0,40 kg	871808
SPST50100	Spray Stop Tape 50+	100 mm x 10 m	0,54 kg	871804
SPST50140	Spray Stop Tape 50+	140 mm x 10 m	0,76 kg	871803
SPST50250	Spray Stop Tape 50+	250 mm x 10 m	1,35 kg	871807
SPST50500	Spray Stop Tape 50+	500 mm x 10 m	2,70 kg	871805
SPST51000	Spray Stop Tape 50+	1000 mm x 10 m	5,40 kg	871806

SPRAY CONTROL TAPE

General description

T-ISS Spray Control Tape is used to upgrade the safety in your pipeline systems. The protection tape makes surroundings a lot safer. Spray Control is made to prevent damages towards human, machinery and pipes by applying the tapes on flanges & valves at chemical plants. The pre-leak detection would help to save unnecessary expenditure for maintenance and repairing. Compared to Spray Shields & Flange Guards, the product can be directly used without any trial chore.

Technical data

Max. temperature resistance: -30 °C up to 75 °C
 Pressure resistance: Up to 15 bar
 Material: Multilayer reinforced high grade vinyl

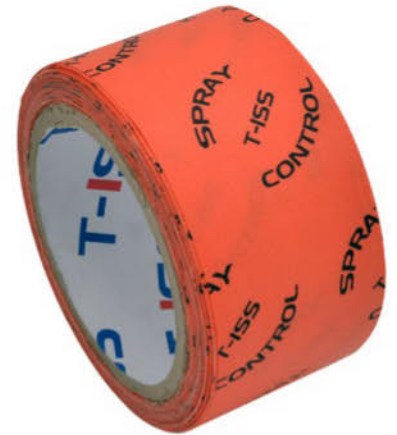

Article number	Description	Dimensions	Weight	Thickness
SPCT0050	Spray Control Tape	50 mm x 10 m	0,3 kg	1 mm
SPCT0100	Spray Control Tape	100 mm x 10 m	0,5 kg	1 mm
SPCT0150	Spray Control Tape	150 mm x 10 m	0,8 kg	1 mm
SPCT0300	Spray Control Tape	300 mm x 10 m	1,5 kg	1 mm

DRIP STOP TAPE - NON LEAK TAPE

General description

T-ISS Drip Stop Tape is easy to use, not using any adhesive components and it will not stick to the hand. The tape is made to stick on components. When applying it needs an overlap of half the width on the tape. The full cure time is approximately 20 – 30 minutes.

Drip Stop Tape can be used even on wet surfaces and pressurized leaking piping up to maximum 3 kg/cm². It will even work under water. When being used in wet areas, it must be winded very tightly. The tape can also be used as a protection layer to prevent corrosion or as electric insulation.

Technical data

Tensile strength: 32,8 kg / cm²
 Elongation at brake: 435%
 Volume resistivity: 6,1 x 10,150
 Dielectric strength: 21 kV / mm
 Dielectric constant: 0,03
 Dissipation factor: 2,01

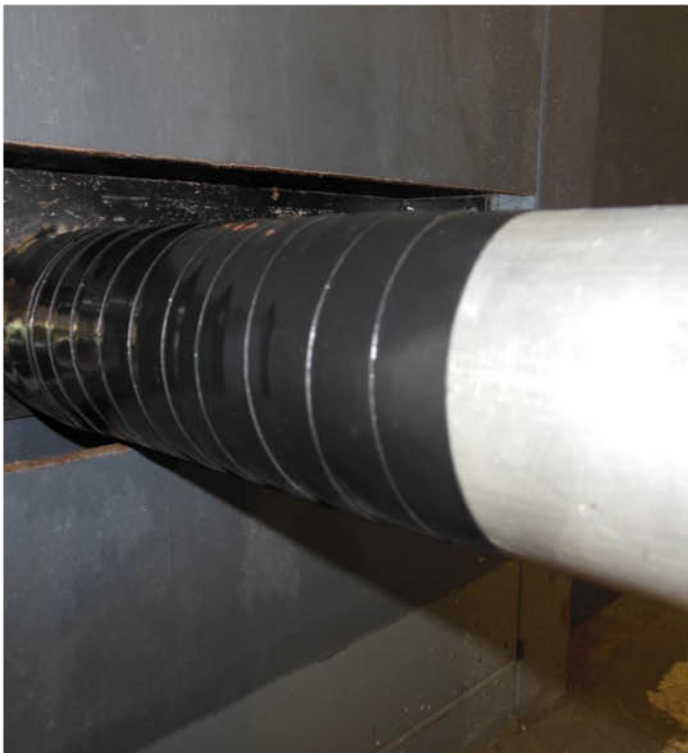

Article number	Description	Dimensions	Weight	Thickness	IMPA
DST025	Drip Stop Tape	25 mm x 10 m	0,1 kg	0,1 mm	812491
DST038	Drip Stop Tape	38 mm x 10 m	0,2 kg	0,1 mm	812492
DST050	Drip Stop Tape	50 mm x 10 m	0,3 kg	0,1 mm	812493

PIPE REPAIR TAPE

General description

T-ISS Pipe Repair Tape is a specially developed resin coated glass fiber cloth, which will set also under water. The fiberglass cloth tape is impregnated with a water activated resin prior to packaging. Normal setting time is approximately 20 minutes, depending on the temperature. The activator is water, salt or fresh. This repair product sets even under water and because of this, it is ideal to use in difficult / wet applications. T-ISS Pipe Repair Tape can be used for corrosion prevention, reinforcement and electrical protection up to 16,000 volts.

Technical data

Maximum pressure: 10 bar

Maximum temperature: 150 °C

One pack of T-ISS Pipe Repair Tape comes with:

- Pipe Repair pouch
- Pipe Repair FastSteel putty
- One pair of protective gloves
- Instruction manual



Article number	Description	Dimensions	Weight	IMPA	ISSA
PRT002	Pipe Repair Tape 2"	50 mm x 1,5 m	0,1 kg	812364	7558802
PRT003	Pipe Repair Tape 3"	75 mm x 2,7 m	0,2 kg	812365	7558803
PRT004	Pipe Repair Tape 4"	100 mm x 3,05 m	0,4 kg	812363	7558804



SOLASFLEX RETRO REFLECTIVE TAPE



**TYPE II Approved A658(18) & MSC 481(102).
Highly weather resistant for continuous outdoor exposure.**

General description

T-ISS SolasFlex Retro Reflective Tape is used for the reflection of SOLAS life saving appliances such as life jackets, life rafts or life boats. Our SolasFlex Retro Reflective Tape is an encapsulated lens sheet provided with a flexible and fully transparent plastic foil. The tape is specially designed for the marine / offshore industry, has a long life span, high clarity and anti-lamination. All our reflective tapes consist of an encapsulated optical design with a high reflective value that is clearly visible from every angle, both in dry and wet conditions.

Our SolasFlex Retro Reflective Tape is type II approved according IMO A658(16), this means it can be used indoor as well as outdoor and is suitable for all applications, extreme weather conditions and continuous outdoor exposure.

By applying SolasFlex Retro Reflective Tape the life saving appliances will be highly visible, when for example helicopter lights are used to search for these objects.



The tape is available as self-adhesive and stitchable.

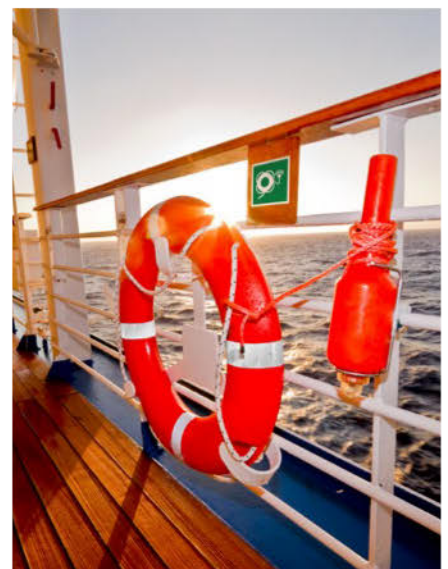



Technical data

Thickness: 0,35 mm (adhesive) or 0,15 mm (sewon)

Benefits & Features

- 2 Versions Sewon & Adhesive
- Tape reflects a clear bright white light
- High reflectivity over a wide range of entrance angles
- Type 2 Solasgrade reflectivity (indoor/outdoor use)
- Other widths available on request

Approvals

- USCG, DNV, Wheelmark, Russian Register, Korean Register, Redensign

Standards

- Complies with IMO Res. A658(16) and meets USCG specification 46 CFR Part 164.

Important warning: reflective tape with a type I approval can only be used on indoor stored lifejackets and life rafts, this is not suitable for lifebuoys, lifeboats and other lifesaving equipment which are exposed to the environment.

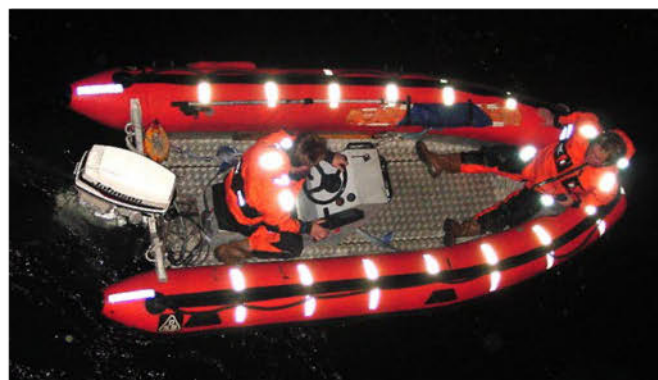

Article number	Description	Dimensions	Weight	IMPA	ISSA
SRTA0050	SolasFlex Retro Reflective Tape Adhesive	50 mm x 45,7 m	1,2 kg	330189	4700704
SRTA1220	SolasFlex Retro Reflective Tape Adhesive	1220 mm x 45,7 m	35,7 kg	-	-
SRTS0050	SolasFlex Retro Reflective Tape Stitchable	50 mm x 45,7 m	1,0 kg	-	-
SRTS1220	SolasFlex Retro Reflective Tape Stitchable	1220 mm x 45,7 m	27,7 kg	-	-

MARINE REFLECTIVE TAPE

General description

T-ISS high-quality self-adhesive Marine Reflective Tape meets several requirements, such as impact resistance and UV protection. The tape is made up of several layers of minuscule prisms which reflect the light perfectly and can be applied to various materials such as steel, plastic, aluminium, fibreglass, etc.

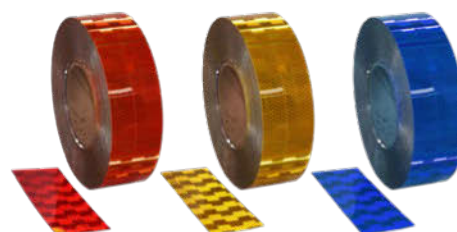

Article number	Description	Colour	Dimensions	Weight
MRTA-050-RD	Marine Retro Reflective Tape adhesive	Red	50 mm x 45 m	1,3 kg
MRTA-050-YE	Marine Retro Reflective Tape adhesive	Yellow	50 mm x 45 m	1,3 kg
MRTA-050-BL	Marine Retro Reflective Tape adhesive	Blue	50 mm x 45 m	1,3 kg

SAFETY MARKING TAPE REFLECTIVE

General description

T-ISS Safety Marking Tape Reflective is an engineering grade reflective tape, used to provide safety and protection. Used to highlight hazards, it is over 200 times more reflective than white paint. Suitable for highlighting hazards and danger areas. Gives a 24/7 protection in and on your vessel.

Technical data

Material: PVC
 Adhesive side: Single sided
 Purpose: Warning and marking

Benefits & Features

- High visibility
- Providing optimal safety to prevent hazardous situations and accidents



Article number	Description	Colour	Dimensions	Weight	IMPA
SMTR050R-L	Safety Marking Tape Reflective left	Red/white	50 mm x 10 m	0,3 kg	-
SMTR100R-L	Safety Marking Tape Reflective left	Red/white	100 mm x 10 m	0,6 kg	-
SMTR050B-L	Safety Marking Tape Reflective left	Yellow/black	50 mm x 10 m	0,3 kg	-
SMTR100B-L	Safety Marking Tape Reflective left	Yellow/black	100 mm x 10 m	0,6 kg	-

ANTI-SLIP TAPE

General description

T-ISS Anti-Slip Tape helps to protect slippery surfaces and to prevent accidents. This tape offers safe working and walking by when applied on stairs and walkways, both indoor and outdoor. Anti-Slip Tape is a mineral coated plastic film with a pressure sensitive adhesive protected by a removable liner. The tape is made using aluminium oxide mineral particles and has a solvent acrylic adhesive material. The tape can be applied in a temperature between 5°C and 50°C.

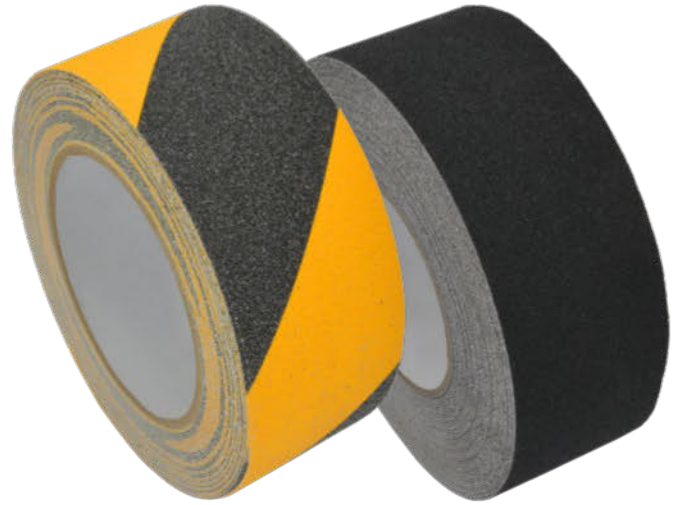

Technical data

Thickness: 0,8 mm tape + 1 - 0,2 mm grit
 Steel adhesion: 1500 g / 25 mm
 Tensile strength: 6 kg / 25 mm
 Elongation / break: 2596
 Application temp: 10°C up to 50°C

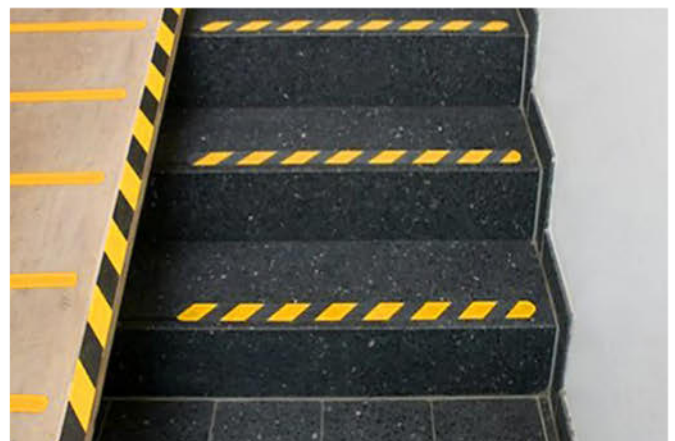
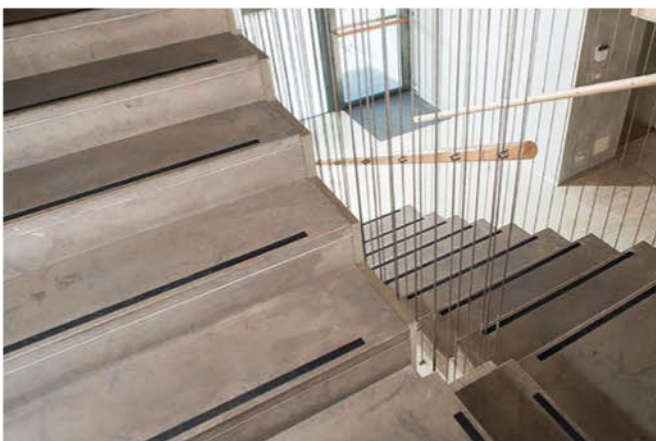

Article number	Description	Colour	Dimensions	Weight
AST0025BK	Anti-Slip Tape	Black	25 mm x 18 m	0,3 kg
AST0050BK	Anti-Slip Tape	Black	50 mm x 18 m	0,6 kg
AST0100BK	Anti-Slip Tape	Black	100 mm x 18 m	1,2 kg
AST0150BK	Anti-Slip Tape	Black	150 mm x 18 m	1,8 kg
AST0050YB	Anti-Slip Tape	Yellow/black	50 mm x 10 m	0,6 kg
AST0100YB	Anti-Slip Tape	Yellow/black	100 mm x 10 m	1,2 kg

FLOOR MARKING TAPE

General description

T-ISS Floor Marking Tape is a tape that was designed for marking floors and walkways to highlight safety hazards. T-ISS Floor Marking Tape has an extremely high durability towards tough surroundings with its excellent adhesive quality. Marking dangerous areas with this floor tape is the first step to increase safety.

Technical data

Material: PVC
 Adhesive: Natural rubber adhesive
 Carrier: 0.135 mm
 PVC Film Appl. temp: 0-50 °C
 Total thickness: 0.15 mm
 Temperature: 0-90 °C
 Tensile strength: 25 N / cm
 Elongation: 150 %

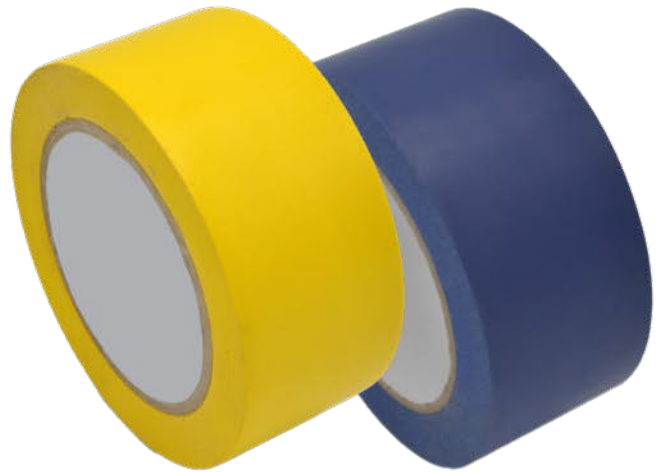

Article number	Description	Colour	Dimensions	Weight
FLT050BU	Floor Marking Tape	Blue	50 mm x 33 m	0,3 kg
FLT050GN	Floor Marking Tape	Green	50 mm x 33 m	0,3 kg
FLT050RD	Floor Marking Tape	Red	50 mm x 33 m	0,3 kg
FLT050YE	Floor Marking Tape	Yellow	50 mm x 33 m	0,3 kg
FLT050BK	Floor Marking Tape	Black	50 mm x 33 m	0,3 kg

BARRIER TAPE

General description

T-ISS Barrier Tape can be used for depositing, marking prohibited or dangerous places. The red/white or black/yellow barrier tape is popular because of the striking hazard colours.

Technical data

Material: Flexible PVC barrier tape
 Length: 500 m
 Weight: 950 gr
 Adhesion: Non-adhesive
 Thickness: 0,03 mm

Benefits & Features

Barrier tape comes in a convenient dispenser box which allows you to obtain the tape length you need, rip off that part, and store the dispenser box in a suitable place. Ideal for tying to fencing, cones & other fixed points.



Article number	Description	Colour	Dimensions
BT080RW	Barrier Tape	Red/white	80 mm x 500 m
BT080YB	Barrier Tape	Yellow/black	80 mm x 500 m

LIGHTLINE PHOTOLUMINESCENT TAPES

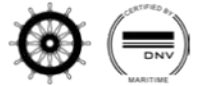

General description

T-ISS manufactures various photoluminescent tapes to indicate escape routes on cruise ships, ferries, roll-on/roll-off ships, offshore installations and many other vessel types. These tapes are being made using PVC, PU or PET materials.

The PU material tape is especially used for applications with rounded surfaces and locations where heavy duty materials are required.

All the photoluminescent tapes complies with the IMO & SOLAS regulations. They have a strong adhesive layer which ensures an extremely good adhesion on many different substrates. The tapes are specially designed for mounting on board of ships and have excellent aging and weather resistant properties. Because of these properties the tapes are suitable for both indoor and outdoor applications/usage. The photoluminescent tapes are not only applicable in the maritime and offshore sector but also in the installation business, such as office buildings and hallways.



Technical data

Elongation 24%
 Weight: 300 g - 40 mm, 375 g - 50 mm, 600 g - 80 mm
 Thickness: 0,175 mm
 Tensile strength: Approx. 5 kg

Luminance intensity (mcd / m ²)	10 min	60 min
Class XXL	200	30
Class M	50	7



Approvals

- Wheelmark
- DNV

Standards

- The product complies with IMO A752(18) and ISO 15370 which include ships and marine technology / low location lighting on passenger ships arrangements.

Please note that the degree of luminance and its longevity can vary depending on the level of excitation achieved. The illumination is influenced by the frequency of the light source and the quality of the illumination provided.

LIGHTLINE PHOTOLUMINESCENT TAPES

T-ISS LIGHTLINE TAPE PET



Other widths available on request

Article number	Description	Dimensions	Quality	IMPA	ISSA
LLTP040CN	LightLine Tape PET neutral	40 mm x 10 m	XXL	-	-
LLTP050CN	LightLine Tape PET neutral	50 mm x 10 m	XXL	-	-
LLTP080CN	LightLine Tape PET neutral	80 mm x 10 m	XXL	-	-

T-ISS LIGHTLINE TAPE PVC

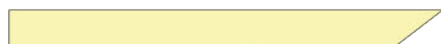

Article number	Description	Dimensions	Quality	IMPA	ISSA
LLTV040CN	LightLine Tape PVC neutral	40mm x 10mtr	XXL	332014	4752014
LLTV050CN	LightLine Tape PVC neutral	50mm x 10mtr	XXL	-	-
LLTV080CN	LightLine Tape PVC neutral	80mm x 10mtr	XXL	332018	-
LLTV040BN	LightLine Tape PVC neutral	40mm x 10mtr	M	332014	4752014
LLTV050BN	LightLine Tape PVC neutral	50mm x 10mtr	M	-	-
LLTV080BN	LightLine Tape PVC neutral	80mm x 10mtr	M	332018	-



According ISO 15370;
Only dead-end corridors

Article number	Description	Dimensions	Quality	IMPA	ISSA
LLTV040CA	LightLine Tape PVC arrow	40mm x 10mtr	XXL	-	-
LLTV080CA	LightLine Tape PVC arrow	80mm x 10mtr	XXL	-	-
LLTV040BA	LightLine Tape PVC arrow	40mm x 10mtr	M	-	-
LLTV080BA	LightLine Tape PVC arrow	80mm x 10mtr	M	-	-



According ISO15370; Please note; this tape is delivered with 3x ES1032, 3x ES1033, 3x ES1004, 3x ES1005 stickers. Other symbols upon request.

Article number	Description	Dimensions	Quality	IMPA	ISSA
LLTV040CE	LightLine Tape PVC escape direction	40mm x 10mtr	XXL	332024	4752024
LLTV050CE	LightLine Tape PVC escape direction	50mm x 10mtr	XXL	-	-
LLTV080CE	LightLine Tape PVC escape direction	80mm x 10mtr	XXL	332028	-
LLTV040BE	LightLine Tape PVC escape direction	40mm x 10mtr	M	332024	4752024
LLTV050BE	LightLine Tape PVC escape direction	50mm x 10mtr	M	-	-
LLTV080BE	LightLine Tape PVC escape direction	80mm x 10mtr	M	332028	-



SAFETY MARKING TAPE PHOTOLUMINESCENT

General description

T-ISS Safety Marking Tape Photoluminescent is used to show contours in spaces. The outlines of (emergency) exits, obstacles and areas to be kept clear or for example, fire extinguishers can be marked with luminous Safety Marking Tapes.

The Safety Marking Tapes Photoluminescent complies with the IMO & SOLAS regulations, have a strong adhesive layer and are suitable for both indoor and outdoor applications/usage.

Technical data

Elongation	24%
Weight:	300 g - 40 mm / 600 g - 80 mm
Thickness:	0,175 mm
Tensile strength:	Approx. 5 kg

Luminance intensity (mcd / m ²)	10 min	60 min
Class XXL	200	30
Class L	50	7

Standards

- The product complies with IMO A752(18) and ISO 15370 which include ships and marine technology / low location lighting on passenger ships arrangements.

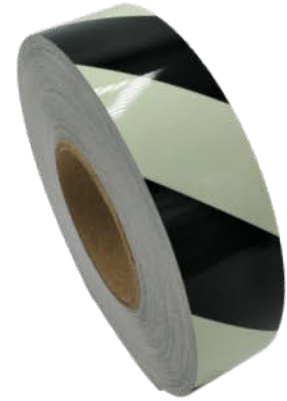

Other widths available on request

Article number	Description	Dimensions	Quality	IMPA	ISSA
SMTV040CG	Safety Marking Tape PVC green	40 mm x 10 m	XXL	332034	4752034
SMTV080CG	Safety Marking Tape PVC green	80 mm x 10 m	XXL	332038	-
SMTV040AG	Safety Marking Tape PVC green	40 mm x 10 m	M	332034	4752034
SMTV080AG	Safety Marking Tape PVC green	80 mm x 10 m	M	332038	-



Other widths available on request

Article number	Description	Dimensions	Quality	IMPA	ISSA
SMTV040CR	Safety Marking Tape PVC red	40 mm x 10 m	XXL	332054	4752054
SMTV080CR	Safety Marking Tape PVC red	80 mm x 10 m	XXL	332058	-
SMTV040AR	Safety Marking Tape PVC red	40 mm x 10 m	M	332054	4752054
SMTV080AR	Safety Marking Tape PVC red	80 mm x 10 m	M	332058	-



Other widths available on request

Article number	Description	Dimensions	Quality	IMPA	ISSA
SMTV040CB	Safety Marking Tape PVC Black	40 mm x 10 m	XXL	332044	4752044
SMTV080CB	Safety Marking Tape PVC Black	80 mm x 10 m	XXL	332048	-
SMTV040AB	Safety Marking Tape PVC Black	40 mm x 10 m	M	332044	4752044
SMTV080AB	Safety Marking Tape PVC Black	80 mm x 10 m	M	332048	-

SECURITY SEAL TAPE

General description

T-ISS offers various layouts of reliable Security Seal Tapes, also called warranty void labels. These are made of tamper evident destructible PET. When using this Security Seal Tape, you can quickly see if your goods have been tampered with. It shows the "OPEN VOID" hidden security message as soon as the warranty tape is removed from the surface of a carton box of other applications. These Security Seal Tapes seal of and provide extra protection.

Our Security Seal Tape can be applied to a large range of surfaces including paper, card, metal, glass and many more. Void tapes are mainly used for forensic intelligence investigation, military, banking security, aviation security, medical packaging seals, electronic goods protection and other.



Technical data

- Adhesion: Pressure sensitive
- Minimum Shelf life: 2 years
- Thickness: 25 Micron
- Colour: Various colour's, layouts and sizes are possible according to the customers demands. Production of individual labels or on roll. Also custom made labels possible.
- Material: PET, Halogen free, NON-PVC

Benefits & Features

Security Seal Tapes help you to reveal tampering or unauthorized access. High value goods need to have a security/safety seal. This seal protects the luxury goods from theft and fraud during shipment and storage. Our Security Seal Tapes reveal the hidden security message when tampering has occurred. Even if someone tries to replace it, the void tape will show that an individual attempted to break into it.

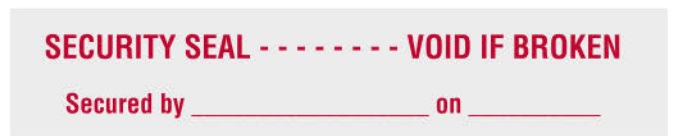

Security Seal Tape (open void tape) provides the best solution when evidence is required of tampering. Our guarantee seal or guarantee tape provide a visible indication of attempt of removal. After removing, since most of adhesive remains on the surface (and little to none on the tape film), the tape film cannot be reused, which is an added security feature against unauthorized reuse of the tape.

Article number	Description	Dimensions	Weight	Thickness
SST035DNB	Security Seal Tape - Do not break	35 mm x 10 m	73 gr	25 mu
SST035VIB	Security Seal Tape - Void if broken	35 mm x 10 m	73 gr	25 mu
SST035CM	Security Seal Tape (custom-made)	35 mm x 10 m	73 gr	25 mu

BIOSOLUBLE HEAT STOP TAPE

General description

T-ISS Biosoluble Heat Stop Tape is a revolutionary new environmental friendly tape and is used for insulation of hot piping systems on board ships. It was specially invented to replace the ceramic fiber tape in the maritime sectors. T-ISS Biosoluble Heat Stop Tape is made of a biosoluble fiber chemical composition which is different from regular ceramic fiber, the biosoluble fiber has a better performance and it is biodegradable. It protects surfaces and lowers temperatures in a highly effective way.

T-ISS Biosoluble Heat Stop Tape is a woven fabric made of superior biosoluble fiber. This special tape contains about 15-18% binder materials which gives it superior heat resistance. Inwoven stainless steel wire and the fiber-glass filament inside will keep the biosoluble fiber tape high temperature performance when it is used.

Benefits & Features

- No cracking and no hardening
- Cold and wet surface application is possible
- ECO friendly
- Temperature resistance: 1000°C

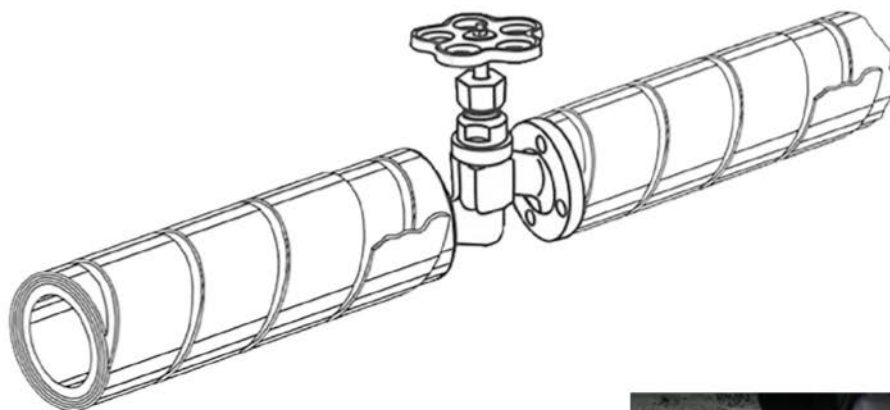

Standards

- Meets SOLAS Regulation II/2/12.2.10
- Complies with MSC 61 (67)
- GTS Verification of Compliance
- EN 14306:2009 + A1:2013

Article number	Description	Dimensions	Weight	Thickness
HST050	Heat Stop BIO Tape	50 mm x 7,7 m	252 gr	3 mm
HST100	Heat Stop BIO Tape	100 mm x 3,3 m	609 gr	12,5 mm

CORROSION STOP ZINC TAPE

General description

T-ISS Corrosion Stop Zinc Tape will prevent galvanic corrosion and protects new and existing steel parts such as bridge supports, pipelines and other marine structures. Corrosion Stop Zinc Tape is made of a high purity zinc with a high tack self-adhesive backing.

T-ISS Corrosion Stop Zinc Tape has a sacrificing role in the oxidation process. Instead of the two metals that are attached to each other, the tape will oxidize and so protect the two other metals. The same principle is put into practice on vessels; anodes are placed on the ship's hull. These anodes will rust instead of the hull which results in a hull that's rust-free for a longer period of time.



Technical data

Material: Zinc layer (39%)
 Adhesive: Acrylate
 Adhesion to steel: >70N /100 mm
 Thickness: 0,1 mm zinc, 0,05 mm adhesive
 Temp. resistance: up to 80 °C
 Shelf life: 12 months

Benefits & Features

The zinc layer on the tape will not be infiltrated by water, gas, etc. Also, the tape will not age due to UV light so there will be no corrosion from the inner layer.



Article number	Description	Dimensions	Weight	Thickness	IMPA
CSZT025	Corrosion Stop Zinc Tape	25 mm x 20 m	429 gr	1 mm	673521
CSZT050	Corrosion Stop Zinc Tape	50 mm x 20 m	771 gr	1 mm	673522
CSZT100	Corrosion Stop Zinc Tape	100 mm x 20 m	1386 gr	1 mm	673523

RUST STOP PETRO TAPE

General description

T-ISS Rust Stop Petro Tape is an anti-corrosion tape which can be applied to all types of steel and steel structures, including pipes and pipelines. The tape provides an excellent resistance to water, acids, alkalies and salts. It is an appropriate long-term solution against corrosion. Even under water, under the ground and in harsh weather conditions, the tape retains its excellent properties and won't peel, harden or crack. The tape is easy to apply and requires a very short processing time. The tape is solvent-free.

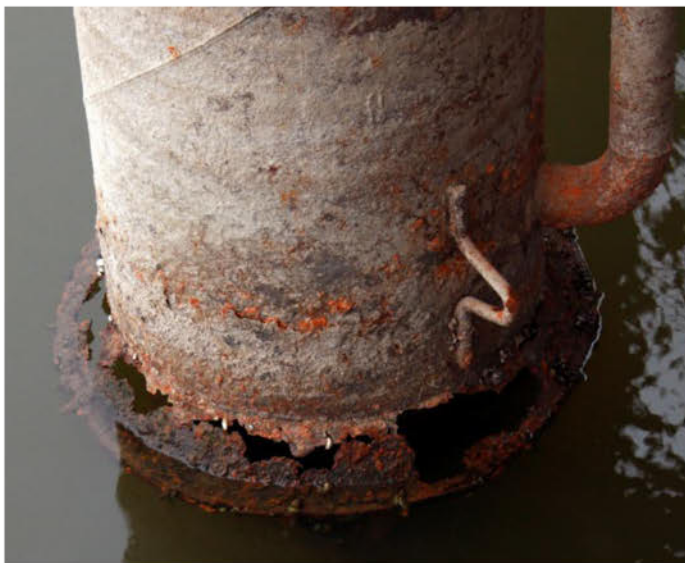

Article number	Description	Dimensions	Weight	Thickness	IMPA
RSPT050	Rust Stop Petro Tape (36 pcs)	50 mm x 10 m	0,7 kg	1,2 mm	812471
RSPT100	Rust Stop Petro Tape (18 pcs)	100 mm x 10 m	1,4 kg	1,2 mm	812472

HATCH COVER BLUELINER TAPE

General description

Extreme weather conditions can cause leakage of your hatch covers, which can lead to damage of the cargo being transported. T-ISS Hatch Cover Blueliner Tape keeps moisture out and ensures a tight seal that's weather and smoke resistant. The tape has an extraordinary strength, great adhesion and is extremely flexible. The tape is easily recognizable by the blue top layer of modified PE material. This material gives the highest protection under extreme conditions.



Technical data

Characteristic: 20 m / self-adhesive SBS bitumenrubber mix
 Heat resistance: -15°C up to 70°C
 Shelf life: 5 years



Benefits & Features

Hatch Cover Blueliner Tape is tested under practical environments and extreme weather conditions. The tape can be installed between 5°C and 40°C, and can withstand -15 to 70°C. Rolls are 20 meter of self-adhesive SBS bitumen rubber compound, mix to a modified blue PE liner and with a release PE Liner.



Article number	Description	Dimensions	Weight	Thickness	IMPA	ISSA
HCT100	Hatch Cover Tape (3 pcs)	100 mm x 20 m	4,5 kg	2 mm	232452	4300310
HCT150	Hatch Cover Tape (2 pcs)	150 mm x 20 m	7,0 kg	2 mm	232453	4300311

FOAM MOUNTING TAPE

General description

T-ISS Foam Mounting Tapes are closed-cell, polyethylene foam, coated with a high tack / high shear acrylic adhesive. It has superior chemical and fuel resistance, and good outdoor weather resistance. It has excellent adhesive performance in the area of tack, shear and adhesion.

High tack permanent adhesive with excellent aging and weather resistant properties specifically designed for mounting and joining nameplates, plastic trim, signs and emblems. Used on board of all types of vessels to install signage or to fix products to a surface.



Technical data

Peel adhesion: PSTC-3.1.8 kg / 25 mm
 Shear strength: PSTC-7 over 72 hours
 Heat resistance: Over 24 hours
 Service temperature: -30 °C ~ 120 °C
 Strength: 1.8 kg/25 mm

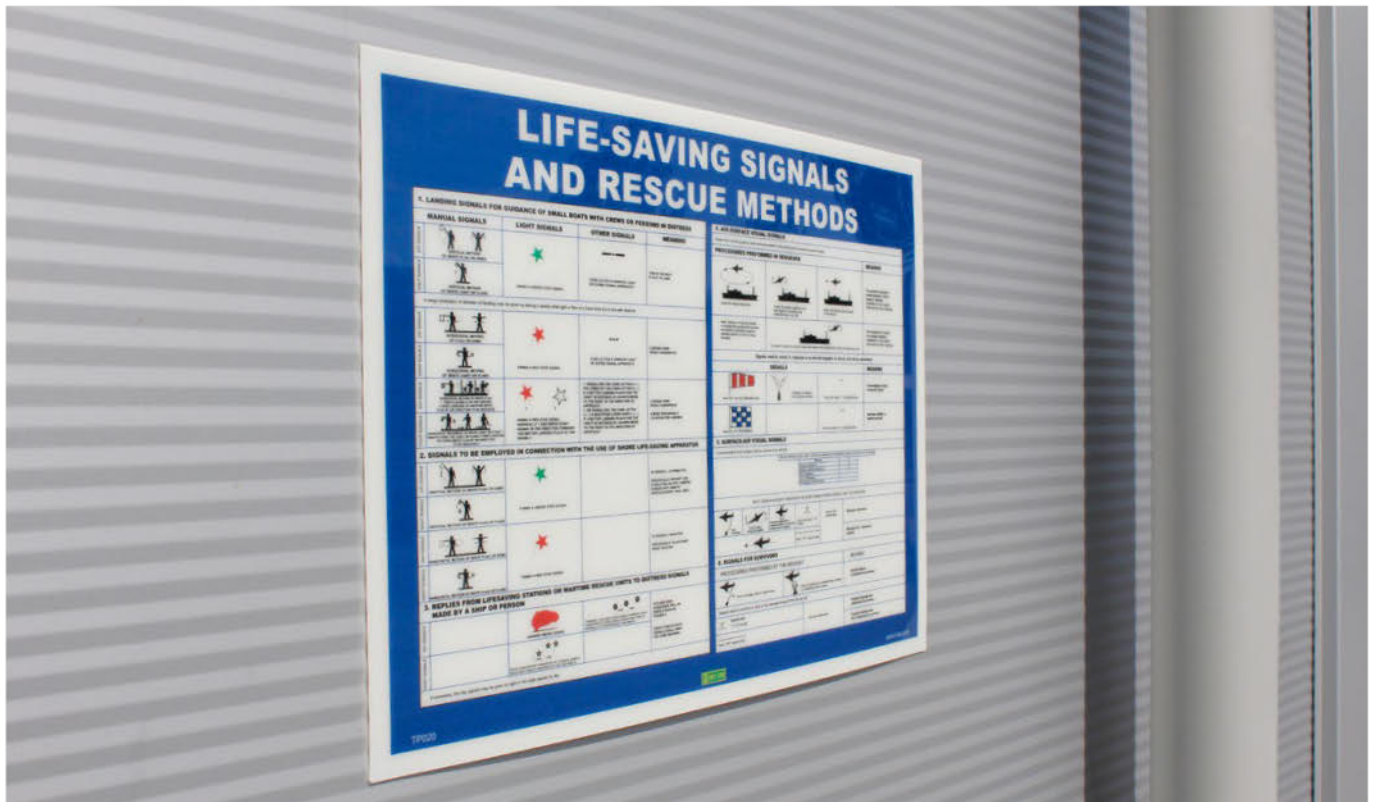

Other widths available on request in 10 and 50 m length

Article number	Description	Dimensions	Weight	Thickness
FMT10-020	Foam Mounting Tape	20 mm x 10 m	0,07 kg	1 mm
FMT10-040	Foam Mounting Tape	40 mm x 10 m	0,10 kg	1 mm
FMT50-055	Foam Mounting Tape	55 mm x 50 m	0,80 kg	1 mm
FMT50-150	Foam Mounting Tape	150 mm x 50 m	1,80 kg	1 mm

HEAT PREVENTION TAPE

General description

Heat Prevention Tape by T-ISS is the ultimate solution for industrial and marine settings where high temperatures pose a challenge. Our specialized tape is specially designed to counteract heat conduction, offering protection in various applications.

Crafted for durability and reliability, this non-flammable tape is a go-to choice in environments exposed to extreme temperatures. Heat Prevention Tape boasts a remarkable heat resistance of up to 200 degrees Celsius. Its robust adhesive property ensures a steadfast bond when applied to steel surfaces, guaranteeing long-lasting performance even in the most demanding conditions.

Constructed with high-quality aluminum foil and fortified with an acrylic adhesive glue, our Heat Prevention Tape is engineered to meet all necessary safety standards. It complies with SOLAS REG. SE126 FIRE PROTECTION MATERIALS FOR CARGO SHIPS (SOLAS REG. II-2/5.3 – 6.2), affirming its reliability and suitability for marine applications.

This Heat prevention tape is ideal for use between floors and walls or for safeguarding wiring harnesses in engine rooms. Its versatility extends to a wide range of scenarios, offering exceptional protection to different kinds of steel connections, pipes, and specialized marine structures.

Benefits & Features

- Temperature resistance up to 200°C: Ensures reliable performance in high-temperature environments.
- Fire retardant: Provides enhanced safety by preventing the spread of fire.
- Excellent adhesion: Strong bonding properties ensure reliability in challenging conditions.
- High tensile strength with Glass Cloth: Offers durability and resilience for long-term use.



Standards

- This product passed all tests perfectly according to SOLAS REG. SE126 FIRE PROTECTION MATERIALS FOR CARGO SHIPS. (SOLAS REG. II-2/5.3 – 6.2).
- Complies with No. MED/3.18a. SOLAS 74, Reg. II-2/3, II-2/5, II-2/6 & X/3, IMO MSC/Circ. 1120, 2000 HSC Code 7 and IMO 2010 FTP Code.

Article number	Description	Dimensions
HPRET050	Heat Prevention Tape	50 mm x 10 m
HRRET100	Heat Prevention Tape	100 mm x 10 m
HPRET150	Heat Prevention Tape	150 mm x 10 m

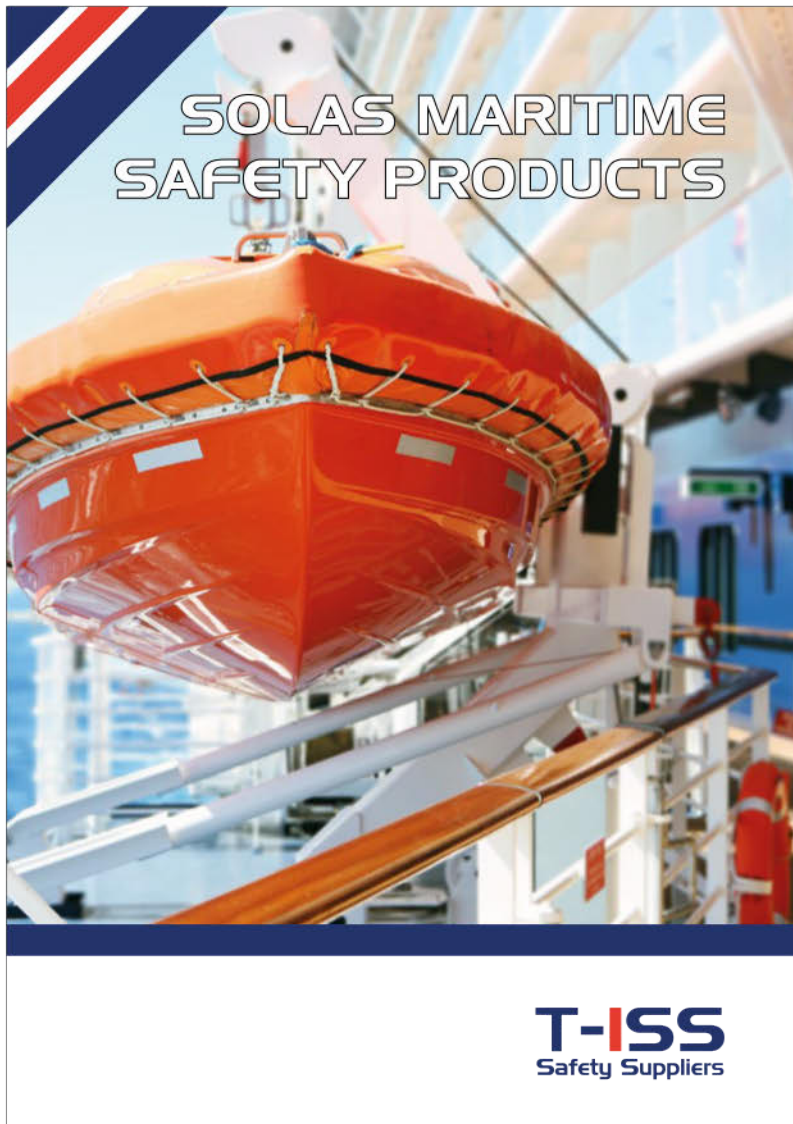

SOLAS MARITIME SAFETY PRODUCTS CATALOG

In addition to our IMO Safety Sign System Products, we also offer our comprehensive 'SOLAS Maritime Safety Products' catalog. In this catalog, you will find life-saving products that are of great importance in operating safely at sea.

Our Safety products all come with the required certificates and approvals and are priced at a very competitive level. To explore our full range of life-saving products, please refer to our 'SOLAS Maritime Safety Products' catalog at t-iss.com. For more information or to obtain a printed copy of our catalog, please do not hesitate to contact us.



HYDROSTATIC RELEASE UNIT (HRU)



LIFERAFT SLASH RESCUE BOAT HOOK



EMERGENCY ESCAPE BREATHING DEVICE (EEBD)



LIFERAFT LIGHT LED WATER ACTIVATED



PILOT LADDER



MAGNETIC LADDER LOCKER



EMERGENCY ESCAPE BREATHING DEVICE (EEBD)



PNEUMATIC LINE THROWER



SAFETY SIGN SYSTEM PRODUCTS & PIPE MARKING CATALOG

T-ISS offers a complete range of safety signage and pipe markings in many variants.

For safety signage we basically offer our photoluminescent PET-X safety signs, which is fully UV resistant, environmentally friendly and does not contain chlorides such as with PVC signs.

In our catalog you find all safety symbols and parts you need to complete your safety sign system, with all possibilities for multiple signs and custom made.

We also offer the best Pipe Marking available on the market, from economy-line pipe markers to our best-selling PolyesPro® Pipe Marking, a colorfast pipe marker that meets the highest quality and durability.

To explore our full range of Safety Sign System Products and Pipe Marking, please refer to our 'Safety Sign System Products & Pipe Marking' catalog at t-iss.com. For more information or to obtain a printed copy of our catalog, please do not hesitate to contact us.



PET-X PHOTOLUMINESCENT SAFETY SIGNAGE



LED ESCAPE SIGNS



LOW LOCATION LIGHTING

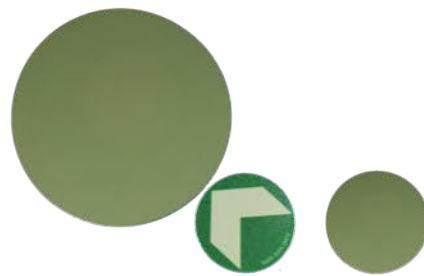

LLL TRAIL DOTS

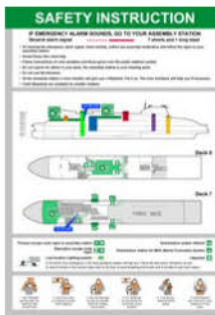

SOLAS SAFETY INSTRUCTIONS



IMO SAFETY POSTERS



PRECOILED PIPE MARKING



MARITIME PIPE MARKING

T-ISS Safety Suppliers
Helmkamp 32 - 34
7091 HR Dinxperlo
The Netherlands

T +31 (0) 315 65 60 60

F +31 (0) 315 65 60 63

E sales@t-iss.com

I www.t-iss.com / solastape.com

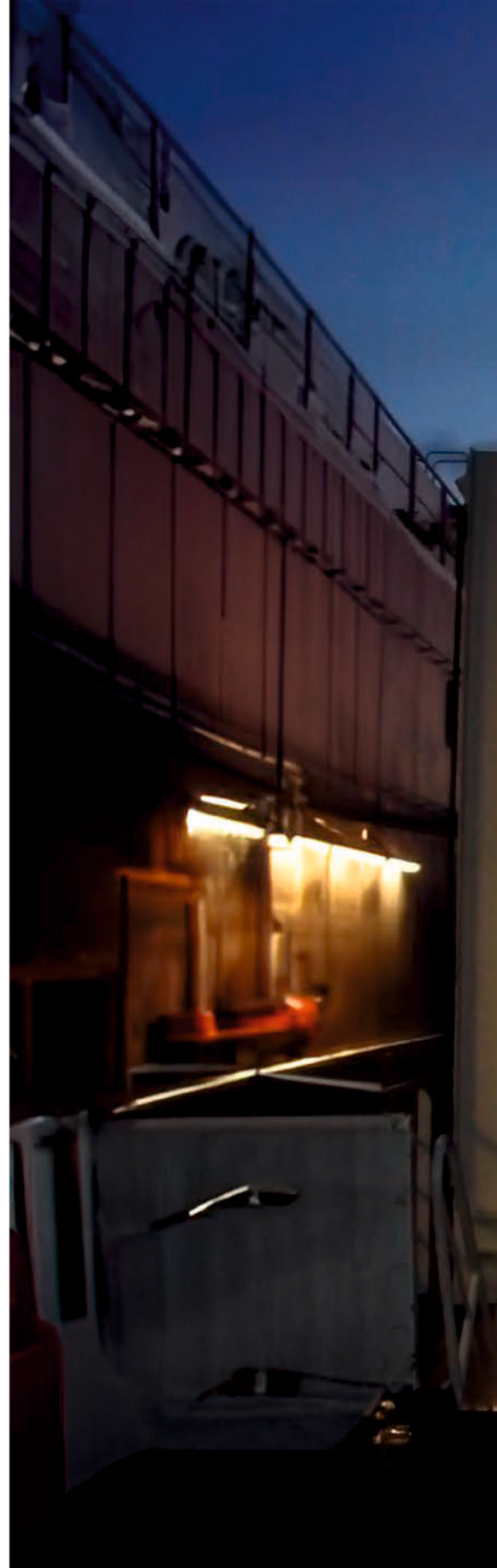

Visit our website:
T-ISS.COM

© COPYRIGHT T-ISS B.V. - all rights reserved

T-ISS
Safety Suppliers